

形式 model	CFP07C-8.5
本体 Basic Comp.	F07B-10
出力 motor kW	0.75 全閉外扇 totally enclosed-fan cooled motor
最高圧力 Max. working pressure	MPa 0.85
回転速度 Compressor speed	min <sup>-1</sup> 1400
吐出空気量 F. A. D.	L/min 80
騒音 Noise level	dB 55
質量 Weight	kg 66
配管出口 Outlet size	G1/4X1
空気タンク容量 Air receiver	L 25
外観寸法 Approx. net dimensions	mm 625X540X760 (700X540X760)

**参 考**  
 PRELIMINARY  
 2020.04.10

形式 model	CFP07C-8.5(100V)
名称 name	オイルフリーコンプレッサ Oil-free Compressor

**ANEST IWATA Corporation**

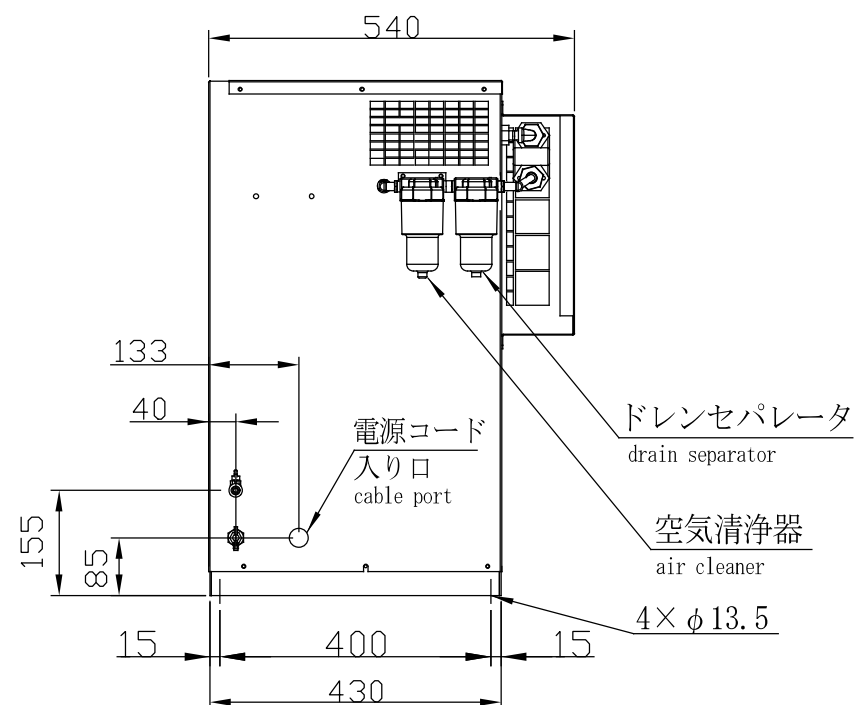
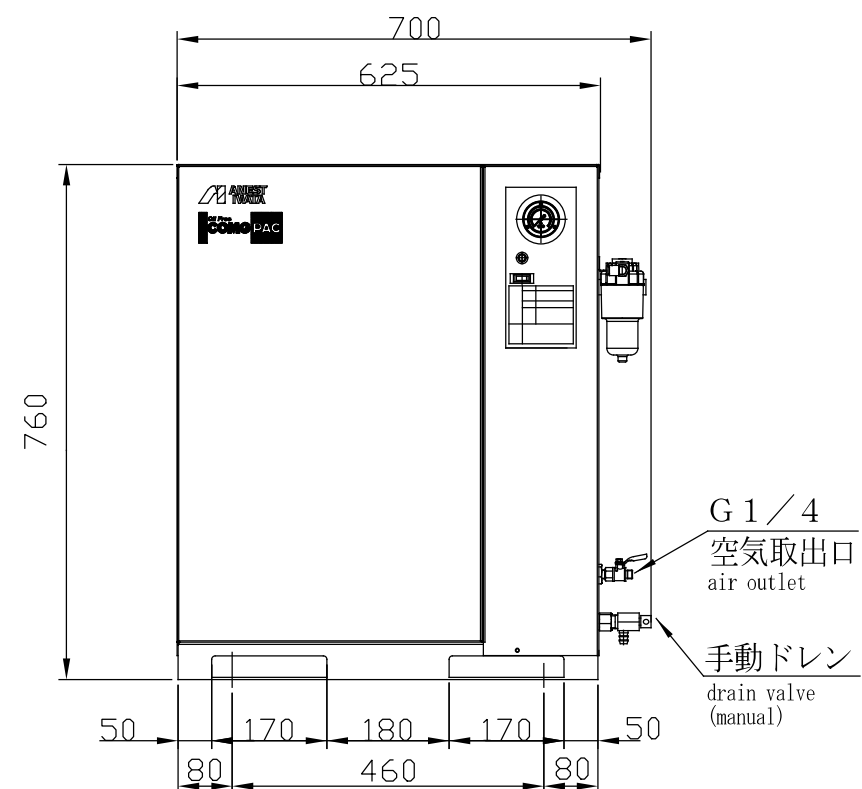
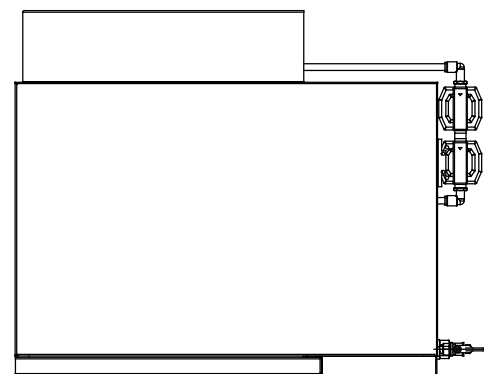

形式 model	CFP07C-8.5D
本体 Basic Comp.	F07B-10
出力 motor kW	0.75 全閉外扇 totally enclosed-fan cooled motor
最高圧力 Max. working pressure	MPa 0.85
回転速度 Compressor speed	min <sup>-1</sup> 1400
吐出空気量 F. A. D.	L/min 70
騒音 Noise level	dB 55
質量 Weight	kg 6.8
配管出口 Outlet size	G1/4×1
空気タンク容量 Air receiver	L 25
外観寸法 Approx. net dimensions	mm 625×540×760 (700×540×760)

参考

PRELIMINARY

2020.04.10

形式 model	CFP07C-8.5D(100V)
名称 name	オイルフリーコンプレッサ Oil-free Compressor

**ANEST IWATA Corporation**

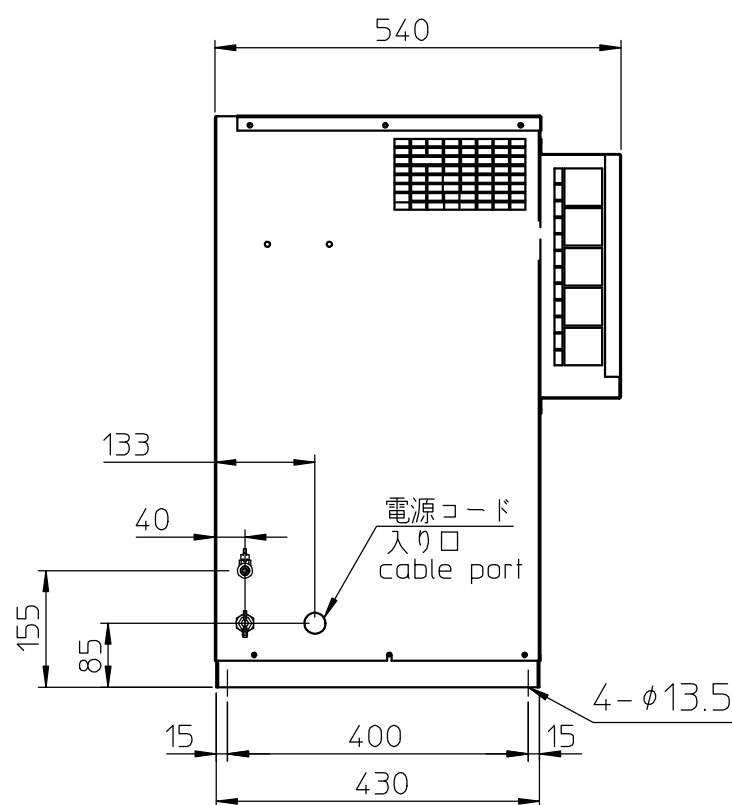
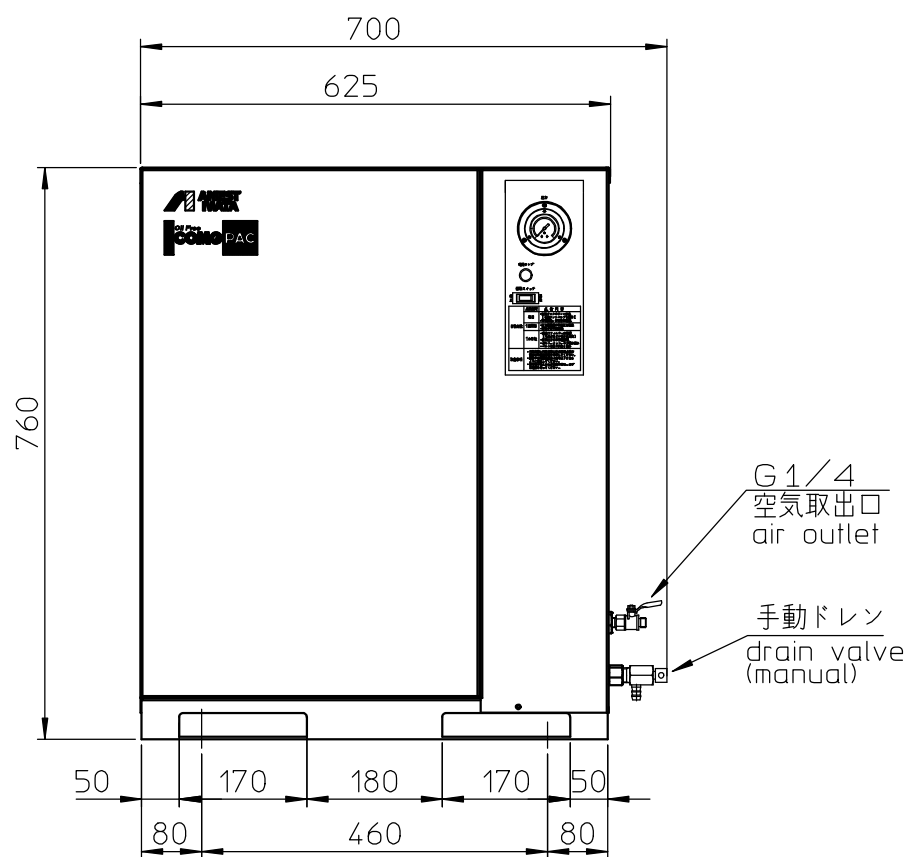
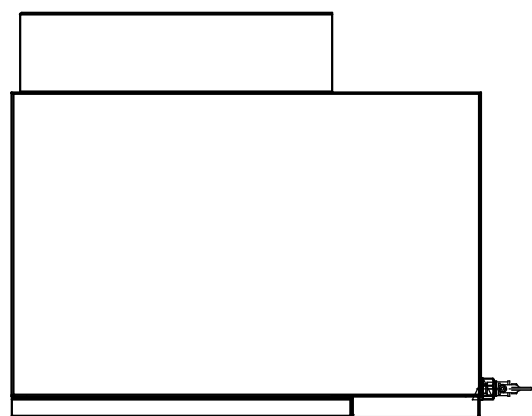

形式 model	CFP07CF-8.5
本体 Basic Comp.	F07B-10
電動機出力 motor kW	0.75全閉外扇 totally enclosed-fan cooled motor
電動機効率クラス motor efficiency class	IE3 プレミアム効率 IE3 premium efficiency
最高圧力 Max. working pressure	MPa 0.85
回転速度 Compressor speed	min <sup>-1</sup> 1400
吐出空気量 F. A. D.	L/min 80
騒音 Noise level	dB 55
質量 Weight	kg 71
配管出口 Outlet size	G1/4X1
空気タンク容量 Air receiver	L 25
外観寸法 Approx. net dimensions	mm 625X540X760 (700X540X760)

注意. 記載の仕様と一部構造は、予告無く変更することがあります。  
NOTE. Structure and specification subject to change without notice.

**参 考**  
PRELIMINARY  
2020.04.10

形式 model	CFP07CF-8.5(200V)
名称 name	コンプレッサ Compressor
<b>ANEST IWATA Corporation</b>	

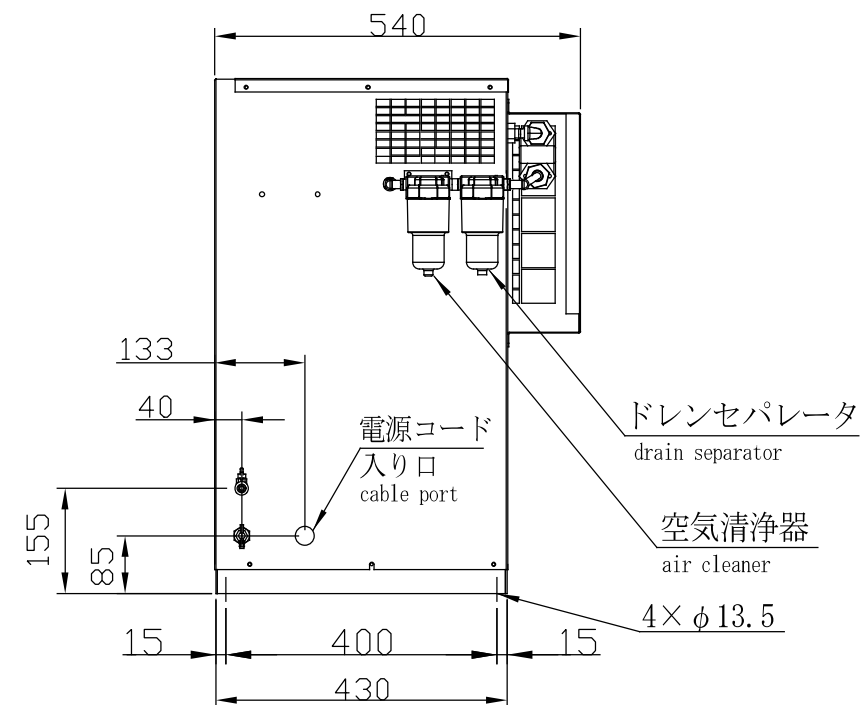
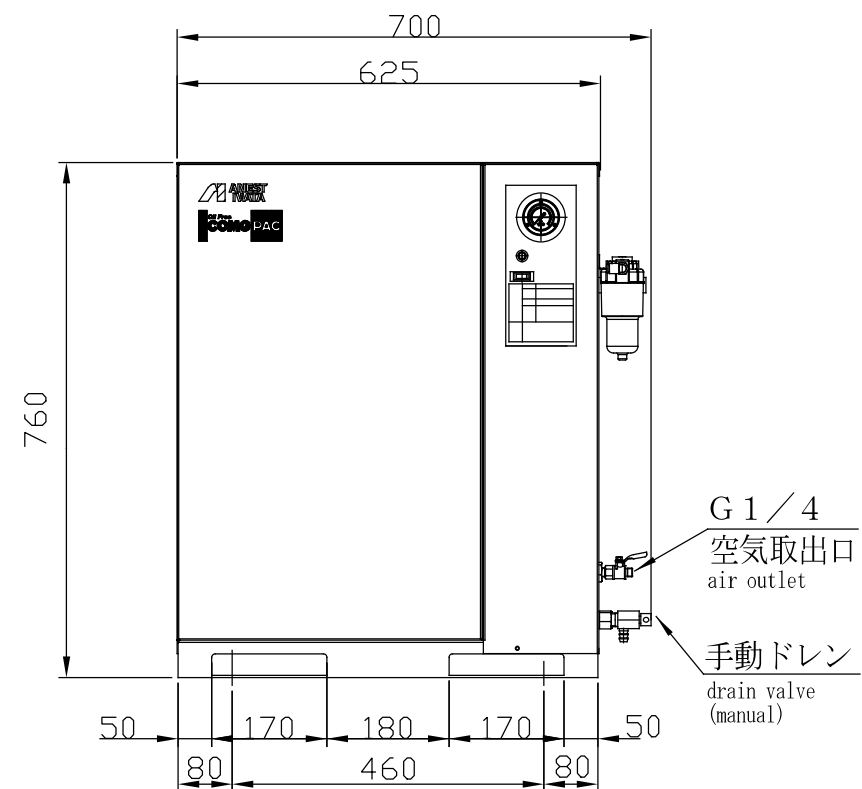

形式 model	CFP07CF-8.5D
本体 Basic Comp.	F07B-10
出力 motor kW	0.75 全閉外扇 totally enclosed-fan cooled motor
電動機効率クラス motor efficiency class	IE3 プレミアム効率 IE3 premium efficiency
最高圧力 Max. working pressure	MPa 0.85
回転速度 Compressor speed	min <sup>-1</sup> 1400
吐出空気量 F. A. D.	L/min 70
騒音 Noise level	dB 55
質量 Weight	kg 73
配管出口 Outlet size	G1/4×1
空気タンク容量 Air receiver	L 25
外観寸法 Approx. net dimensions	mm 625×540×760 (700×540×760)

**参 考**  
 PRELIMINARY  
 2020.04.10

形式 model	CFP07CF-8.5D
名称 name	オイルフリーコンプレッサ Oil-free Compressor

**ANEST IWATA Corporation**