

形式 model	CFP22CF-8.5
本体 Basic Comp.	F223BP-10
電動機出力 motor kW	2.2 全閉外扇 totally enclosed-fan cooled motor
電動機効率クラス motor efficiency class	IE3 プレミアム効率 IE3 premium efficiency
最高圧力 Max. working pressure	MPa 0.85
回転速度 Compressor speed	min <sup>-1</sup> 1100
吐出空気量 F.A.D.	L/min 260
騒音 Noise level	dB 56
質量 Weight	kg 145
配管出口 Outlet size	Rc3 /8X1
空気タンク容量 Air receiver	L 39
外観寸法 Approx. net dimensions	mm 890X655X985 (1023X655X985)

注意. 記載の仕様と一部構造は、予告無く変更することがあります。  
NOTE. Structure and specification subject to change without notice.

参考  
PRELIMINARY  
Sep.11.2017

形式 model	CFP22CF-8.5
名称 name	コンプレッサ Compressor

**ANEST IWATA Corporation**

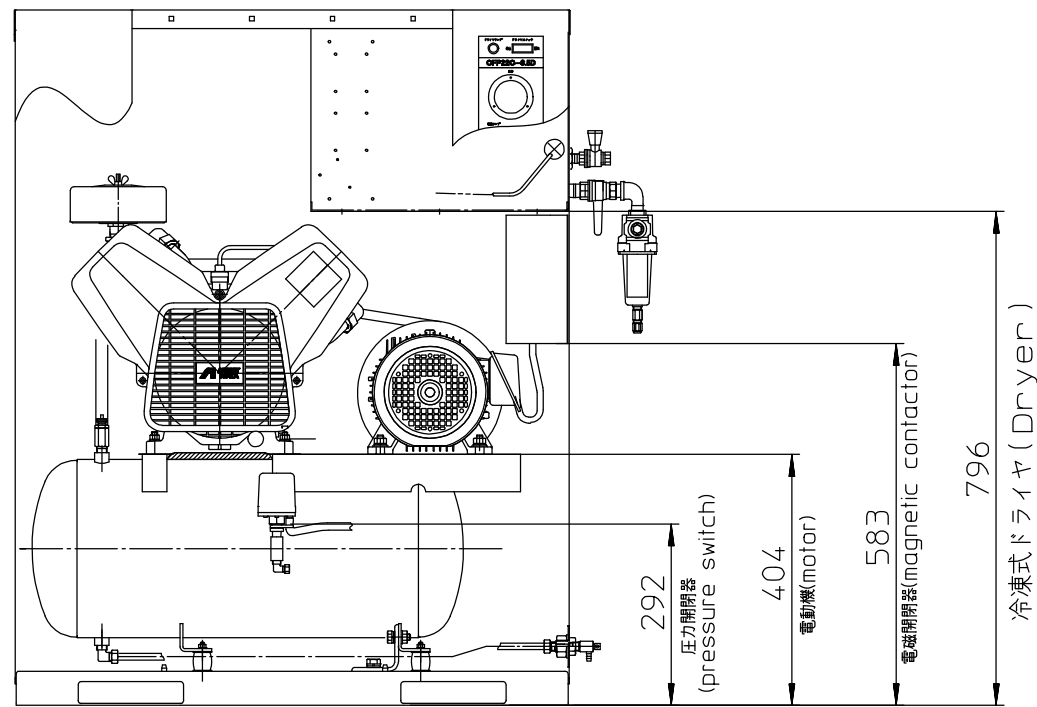
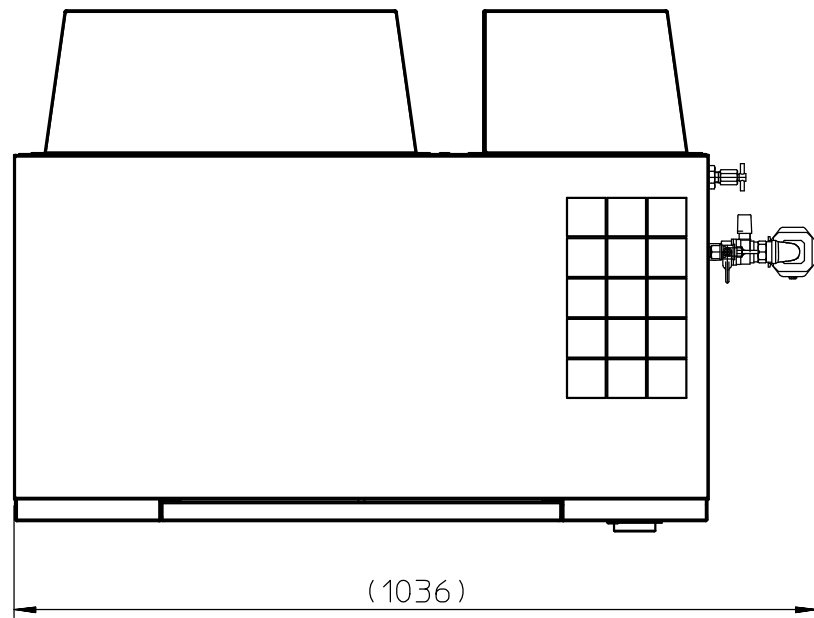

冷凍式ドライヤ(Dryer)

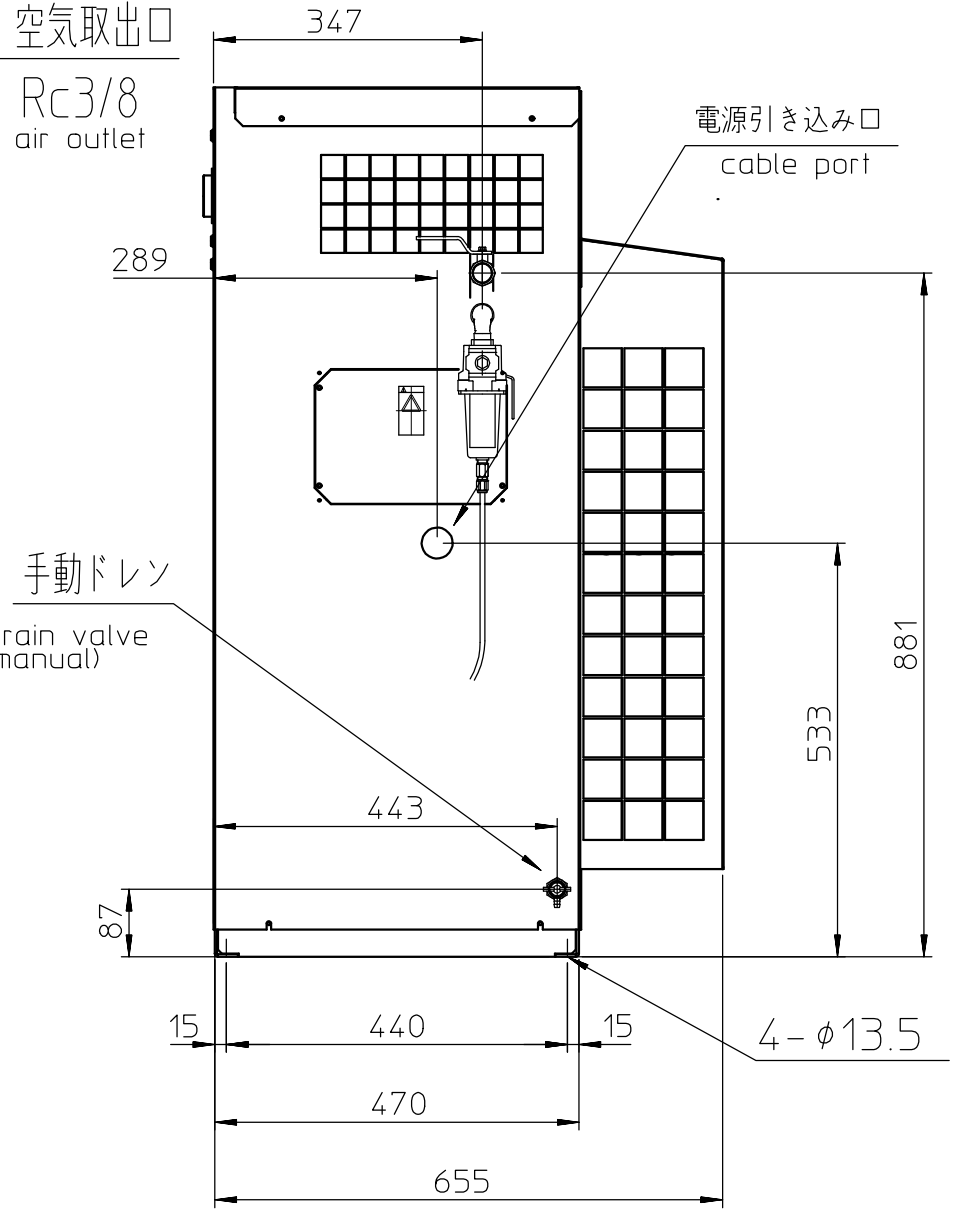
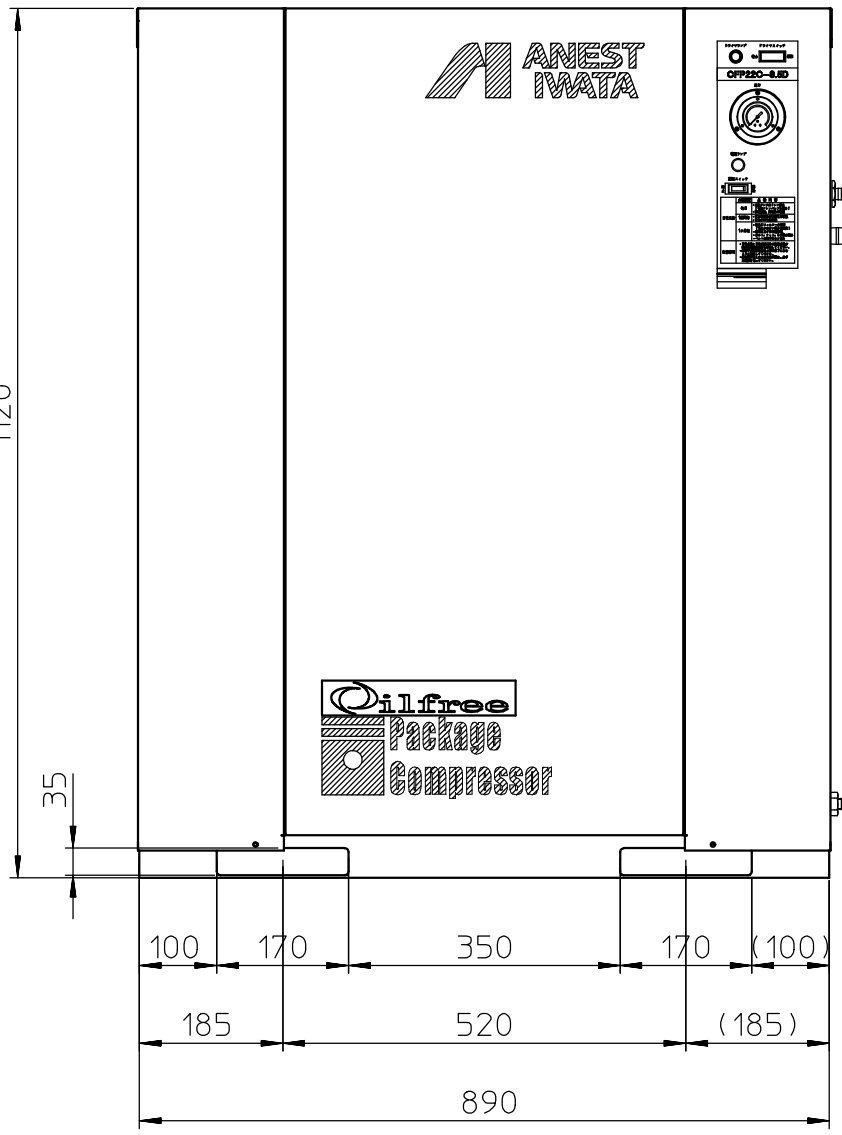

形式 model	CFP22CF-8.5D
本体 Basic Comp.	F223BP-10
電動機出力 motor kW	2.2 全閉外扇 totally enclosed-fan cooled motor
電動機効率クラス motor efficiency class	IE3 プレミアム効率 IE3 premium efficiency
最高圧力 Max. working pressure	MPa 0.85
回転速度 Compressor speed	min <sup>-1</sup> 1100
吐出空気量 F.A.D.	L/min 260
騒音 Noise level	dB 56
質量 Weight	kg 160
配管出口 Outlet size	Rc3 /8X1
空気タンク容量 Air receiver	L 39
外観寸法 Approx. net dimensions	mm 890X655X1120 (1036X655X1120)

参考  
PRELIMINARY  
Sep.11.2017

形式 model	CFP22CF-8.5D
名称 name	コンプレッサ Compressor
<b>ANEST IWATA Corporation</b>	