

A 矢視図

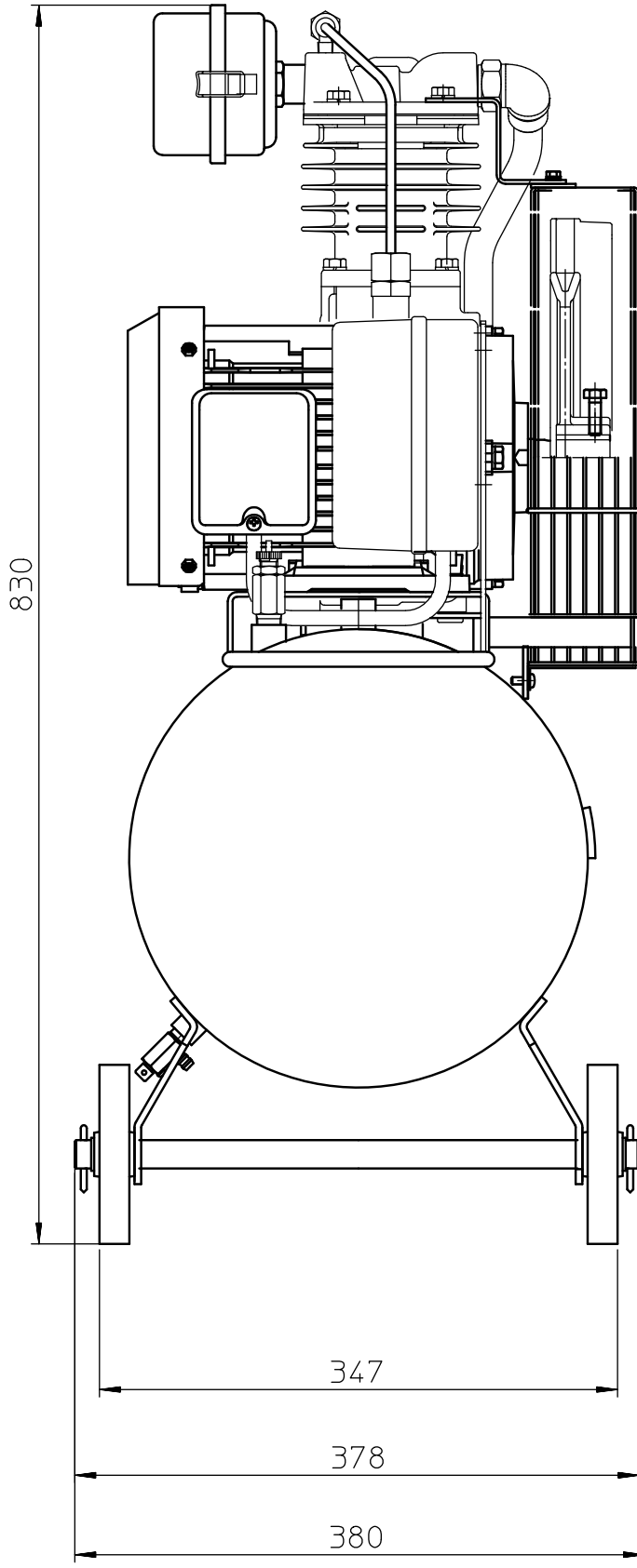
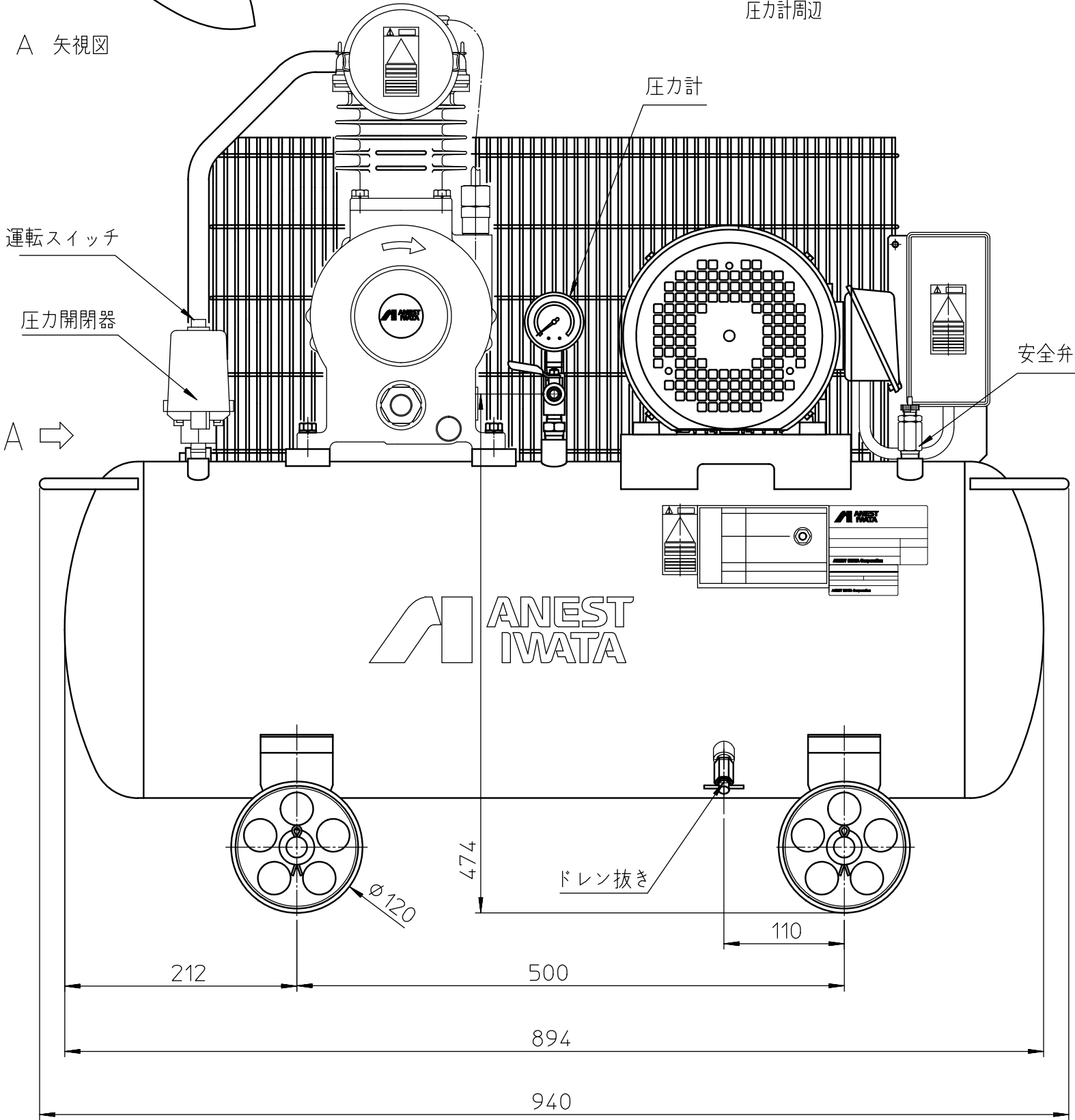

形式 model	TLP15EF-10
本体 Basic Comp.	LS20C
電動機出力 motor kW	1.5 [全開外扇]
電動機効率クラス motor efficiency class	IE3 プレミアム効率
最高圧力 Max. working pressure	MPa 1.0
回転速度 Compressor speed	min ⁻¹ 1240
吐出空気量 F. A. D.	L/min 170
騒音 Noise level	dB 69
質量 Weight	kg 80
配管出口 Outlet size	G1/4X1 (ボールバルブ)
空気タンク容積 Air receiver	L 65
外観寸法 Approx. net dimensions	mm 940X380X830

参考
PRELIMINARY
2015.06.01

形式 model	TLP15EF-10
名称 name	レシプロコンプレッサ Piston Compressor

ANEST IWATA Corporation